

WOODWORKER'S WJOURNAL

"America's leading woodworking authority"™

Classic Plan

Coopered Door Cabinet

In this plan you'll find:

- Step-by-step construction instruction.
- A complete bill of materials.
- Construction drawings and related photos.
- Tips to help you complete the project and become a better woodworker.

These plans are best viewed with Adobe Reader installed on your computer. If you want to get a free copy, visit:
<http://adobe.com/reader>.



Coopered Door Cabinet

Door in the round adds a new dimension

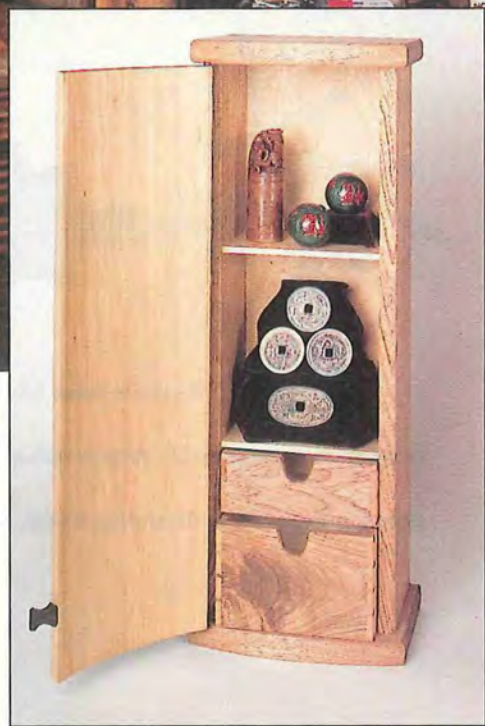
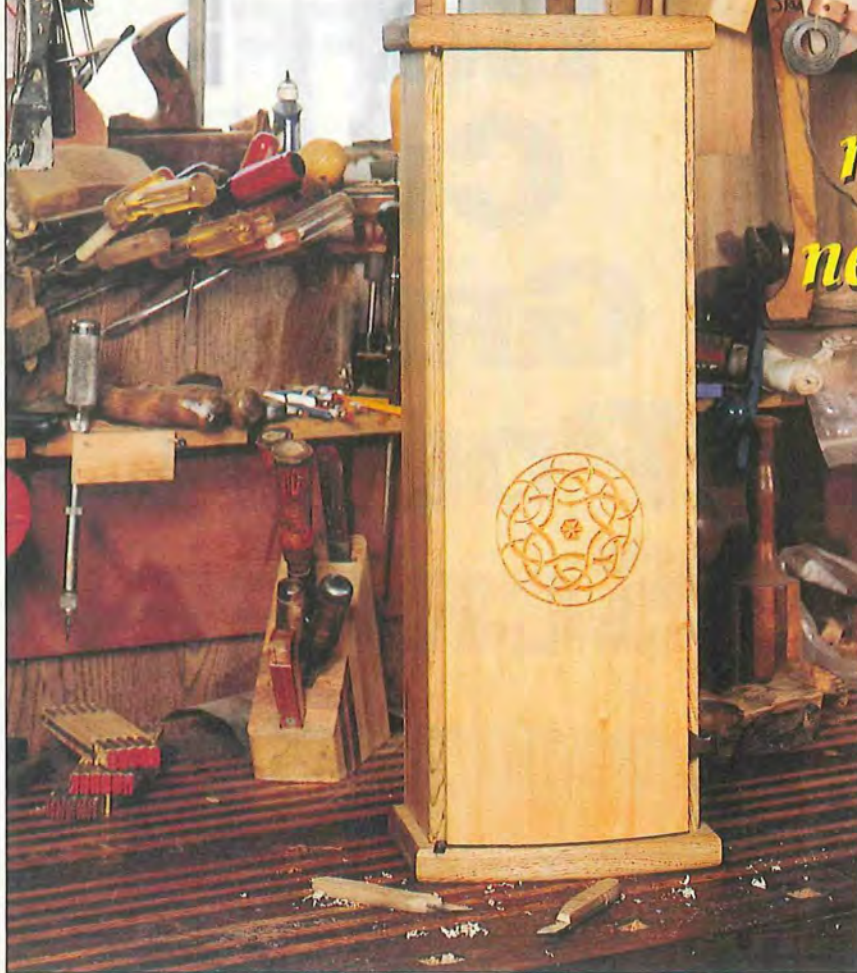

Designer Craig Moro recently thumbed through James Krenov's *The Fine Art of Cabinetmaking*, which inspired him to try a coopering project. The result, which we offer here, makes a unique cabinet that adapts to a variety of uses, depending on how you choose to customize the interior. From materials he had on hand, Craig chose an appealing combination of basswood, butternut, and a bit of rosewood. He derived the chip-carved knotwork on the door from a centuries-old Persian design.

Craig designed his cabinet with two drawers and three shelves, but you can easily adapt the interior to any number of uses.

Before You Start

Craig coopered and sized the door first, then fit the cabinet to it. He fine-tuned the fit of the door to the cabinet when it came time to hang it. Craig chose basswood for the door both for its stability and its carvability. If you don't intend to chip-carve the decorative knotwork on your door, you may want to choose a more richly grained material.

Craig used offset knife hinges for hanging the cabinet door. Straight knife hinges or pivot hinges would also work, provided they mount on the ends of the door and remain mostly invisible. If you select brass knife hinges, you may want to choose a wood for the door pull that complements brass. Craig opted for bronze-finish hinges because they go well with the rosewood he used for his pull.

Cooper the Door

Step 1. Face-joint and plane a 10x28" piece of 3/4"-thick basswood to 9/16" thick. Joint one edge, then select the better face and mark it "outside."

Step 2. Tilt your tablesaw blade to 5° from perpendicular. Bevel-rip the following widths in sequence: 1 1/16", 1 3/16", 1 7/8", 1 13/16", and 1 1/16". Note: Bevel the two outside pieces—the 1 1/16" widths—on the *inside* edge only, leaving the outside edge square. (See *figure 1* for an end view of the beveled parts.) For the three interior parts, bevel-rip one edge, then turn the piece end for end (without flipping it over) and bevel-rip the opposite edge. Now, number the parts in sequence and mark the outside face on each.

Step 3. Joint the mating (beveled) edges of all door parts. (Craig set his jointer to remove 1/32" of stock. Rather than attempting to set the jointer fence to match the 85° bevel, he bevel-ripped one edge of a 2x4 carrier board to 85° and adhered each part to it with double-faced tape for jointing.)

Step 4. Make the clamping form and wedges as described in "Making the Clamping Form" on *page 5*. Test-fit the door parts in the form, aligning the ends. Insert opposed wedges along both sides of the form to squeeze the joints tight (*photo A*). Adjust the form's fit as necessary. Varnish and then wax

BILL OF MATERIALS

PART	T	W	L	MTL.	QTY.
CABINET					
A Door* **	1/2"	7"	22 1/2"	B	1
B Top/Base*	1 5/16"	6 1/2"	8 7/8"	BN	2
C Sides*	1 1/16"	5 1/4"	22 5/8"	BN	2
D Back*	1/4"	6 15/16"	23 1/8"	BP	1
E Shelves*	1/4"	4 3/8"	6 15/16"	B	3
DRAWERS					
F Front—small*	1/2"	2 3/8"	6 3/8"	BN	1
G Front—large*	1/2"	4 1/8"	6 3/8"	BN	1
H Back—small*	3/8"	2 3/8"	6 3/8"	B	1
I Back—large*	3/8"	4 1/8"	6 3/8"	B	1
J Sides—small*	1/4"	2 3/8"	4 5/16"	B	2
K Sides—large*	1/4"	4 1/8"	4 5/16"	B	2
L Bottoms*	1/4"	3 5/8"	6 1/16"	BP	2
OTHER					
M Door pull*	5/8"	3/4"	1 1/4"	R	1
N Mounting cleats*	3/8"	2 1/2"	6 1/2"	H	2

*Parts cut to final size during construction. Please read all instructions before cutting.

**Part edge-glued from narrower stock.

MATERIALS LIST

B—basswood
BN—butternut
BP—birch plywood
R—rosewood
H—hardwood

SUPPLIES

3/8" dowel stock; 1/4" dowel stock; oil finish.
(For other supplies, see Sources listed at end of article.)

Figure 1

Bevel-rip the door parts in sequence

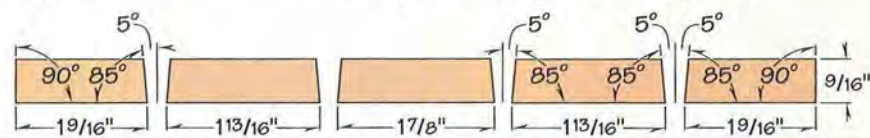

the form edges to prevent any glue squeeze-out from adhering it to the door.

Step 5. Apply glue to the mating edges of the door parts and place them in the form. (We started with the middle and adjoining pieces, then added the two outer parts.) Align the ends of the parts, then insert the wedges to apply uniform clamping pressure. Work carefully to keep the door aligned square in the form. Allow the glue to dry for 12 hours.

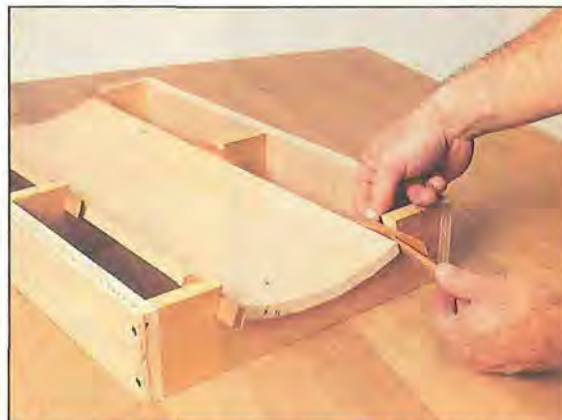
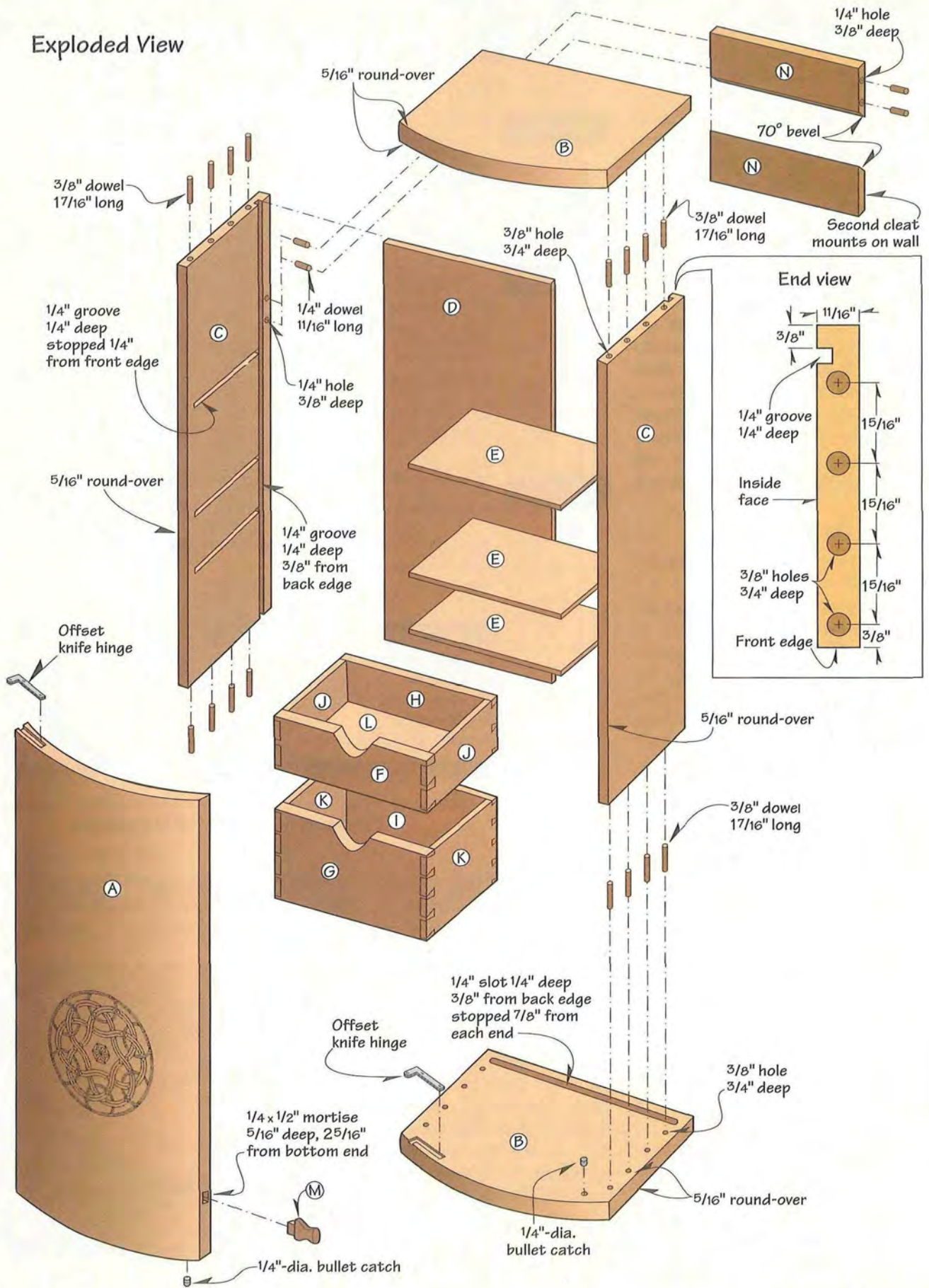

Photo A: Clamp the door parts into the form using opposed wedges, then check to make sure the door is square to the form.

Exploded View



Step 6. To trim the door edges, first remove the door from the form. Next, make a carrier as shown in *figure 2* and *photo B*. Center the door on the carrier and clamp as shown. With your blade set at 90°, rip equal amounts of stock from both edges to 7" final width.

Step 7. Remove any twist from the door edges. If you have an 8" jointer, one light pass should be sufficient. Otherwise, cut two sheets of 100-grit sandpaper into 2"-wide strips, then tape the strips end-to-end in two lines 5½" apart. Next, place the door on the sandpaper strips crown side

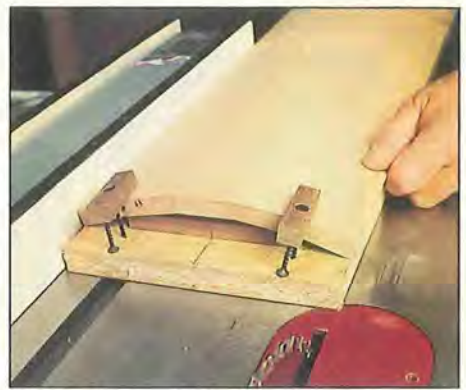
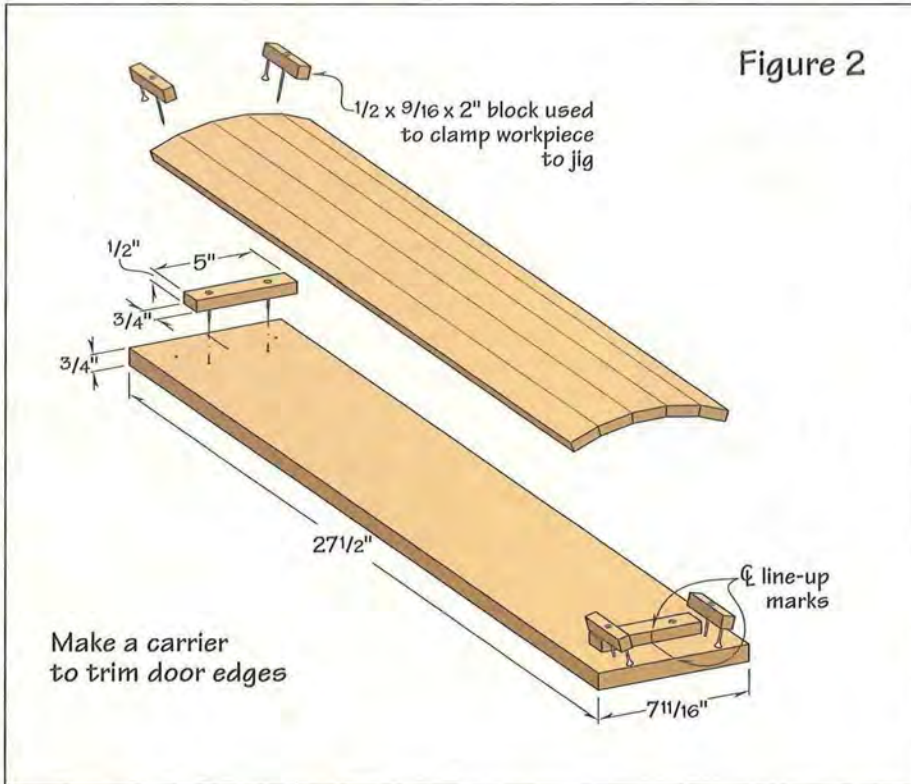

Photo B: Square the door on the carrier and clamp firmly. Note that we sized the cross shims at both ends to support the door under the clamps at the first joints.



up. Applying light pressure, slide the door back and forth along the sandpaper strips until you've sanded away all unevenness and made solid contact all along both edges.

Step 8. Using a sliding cutoff table on your tablesaw (or miter gauge with extension), square one end of the door. Then, crosscut the other end to 22½" long.

Step 9. Plane or sand both faces of the door to remove the facets and create a smooth curvature. A flat plane or sanding block will work fine for the outside face. For the inside face, make a sanding block that roughly matches the door's curvature. Note: You may elect not to remove the tiny facets on the door's inside face.

Making the Clamping Form

Crosscut a 1" length from the same end of all five door parts. Align and edge-glide the cutoffs in sequence using cyanoacrylate glue. Note: You'll use this glue-up to make a template for tracing the coopered arc onto the clamping form blanks.

Cut three 13¼" lengths of 1x4 pine stock. Using the template you just made from the door part cutoffs, center and

trace the arc onto one blank where shown on the drawing *below*. Using a straightedge, extend the outside facets of the arc to add ½" of width on both edges. Then, square a line from each end of the arc to the top edge of the blank.

Bandsaw the cutout on the marked blank, staying as close to the line as possible. Note: The cut needn't be absolutely precise. Test-fit the coopered template in the

cutout to make certain the door will fit. Now, use this blank as a template to make cutouts in the two remaining blanks. Bandsaw both to shape.

From ¾" plywood, rip and crosscut two 3½x24" sides. Assemble the forms and sides, placing one form at each end and centering the third between them.

From 1" stock, cut twelve 5/16x3" wooden wedges. If necessary, sand the mating edges to ensure that the wedges slide smoothly.

Making forms for clamping the coopered door

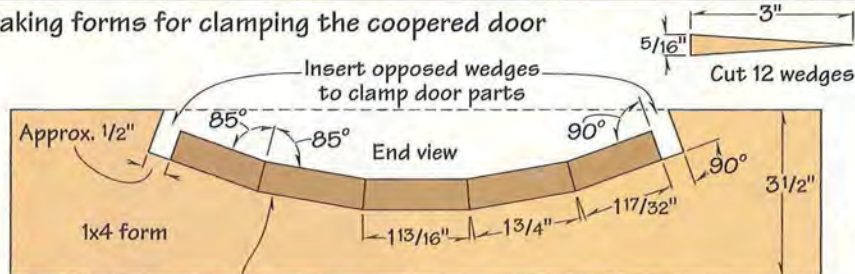

Step 1: Edge-glide door-part cutoffs, then use as template to establish shape of cutout

Step 2: Cut blanks to shape

Insert a pair of opposed wedges in both gaps on each clamping form (12 wedges total)

Now, Build the Cabinet

Step 1. Face-joint and plane a 7x20" piece of 5/4 butternut stock to 15/16" thick. Joint one edge. From this piece, crosscut the top and base (B) to 87/8" long.

Step 2. Using a set of trammel points, lay out the rounded front edge of the top by drawing a centered 14 1/2" radius that peaks 6 1/2" from the back edge. To do this, temporarily adhere a 9" length of scrap stock to the back edge of the top as shown in figure 3. Scribe the arc on the top blank. Note: This radius does not quite match the door's radius.

Step 3. Stack the top and base blanks using double-faced tape. Bandsaw the front edge to shape, keeping your blade outside the line. Sand to the line using a disc sander, then separate the pieces.

Step 4. To make the sides, face-joint and plane a 5 1/2 x 48" piece of 4/4 butternut to 1 1/16" thick. Joint one edge, then rip the stock to 5 1/4" wide. To determine the length of the sides, add 1/8" to your door length, then crosscut the two sides (C) to this dimension. (Ours measured 22 5/8" long.)

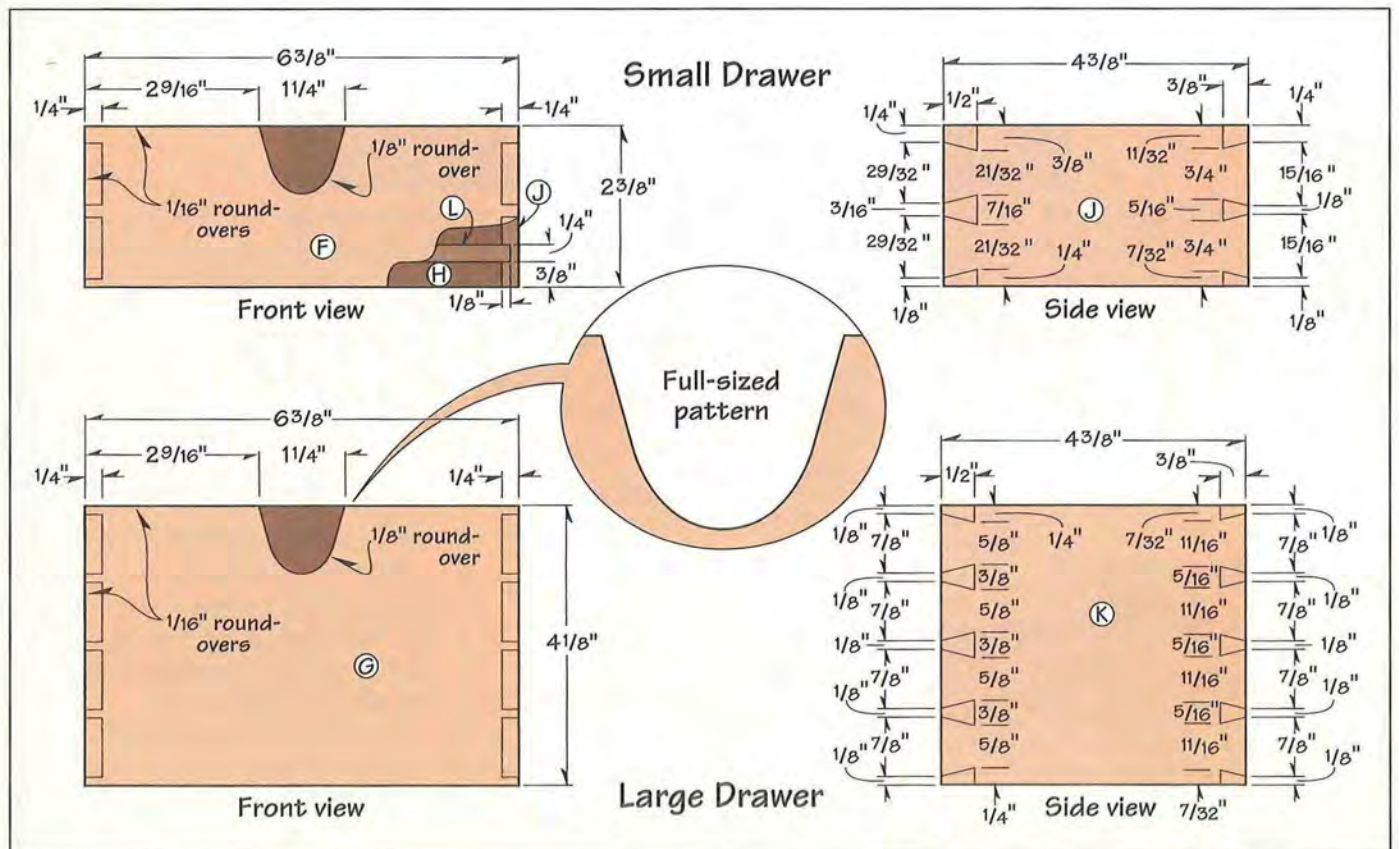
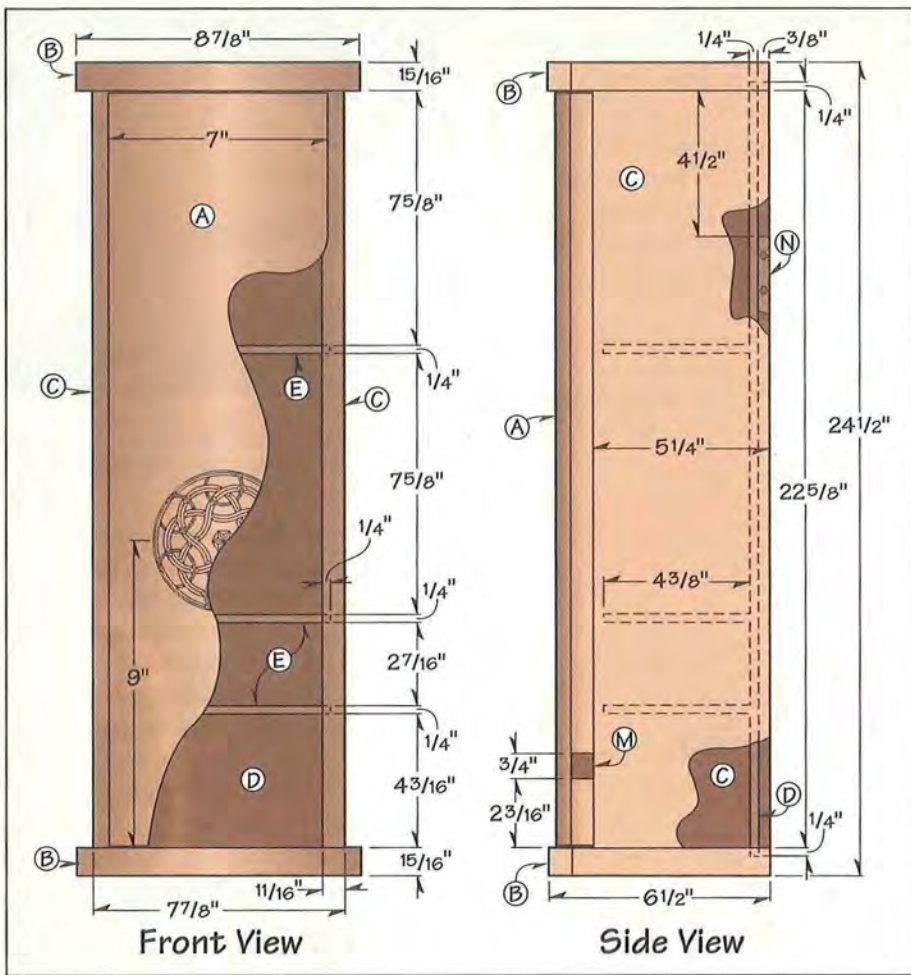
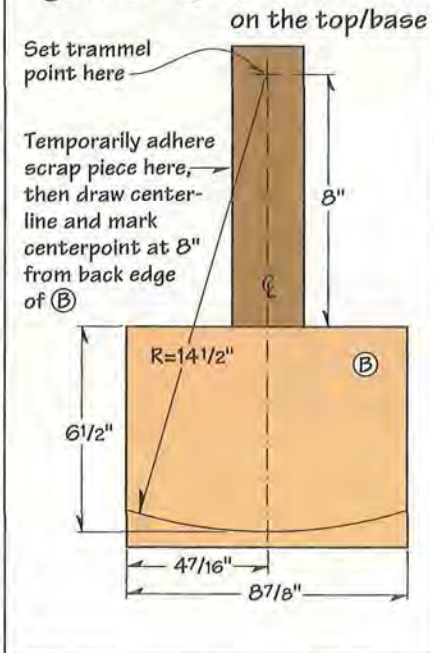

Figure 3 Laying out the radius on the top/base



Step 5. Select the outside face on each side and rout a $\frac{5}{16}$ " round-over along the outside front edge of these two parts. Next, round over both ends and the front edge of the top and base (along both faces) in end-edge-end sequence.

Step 6. Using a doweling jig, lay out and drill four $\frac{3}{8}$ " holes $\frac{3}{4}$ " deep in both ends of the sides where dimensioned on the Exploded View detail. From $\frac{3}{4}$ " scrap, cut a $5 \times 6\frac{1}{2}$ " rectangle to use as a fence for transferring the hole centerpoints. Center it on the base from side to side, align the back edges, then clamp it to the base.

Step 7. Insert dowel centers in the four holes in the bottom end of a side. (See figure 4.) Place the side tight against the fence, align the back

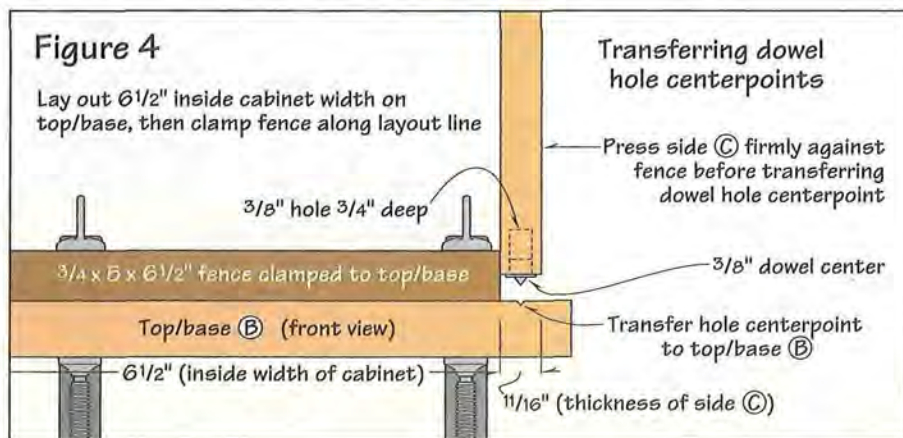

Chip-Carved Knotwork

Full-sized pattern

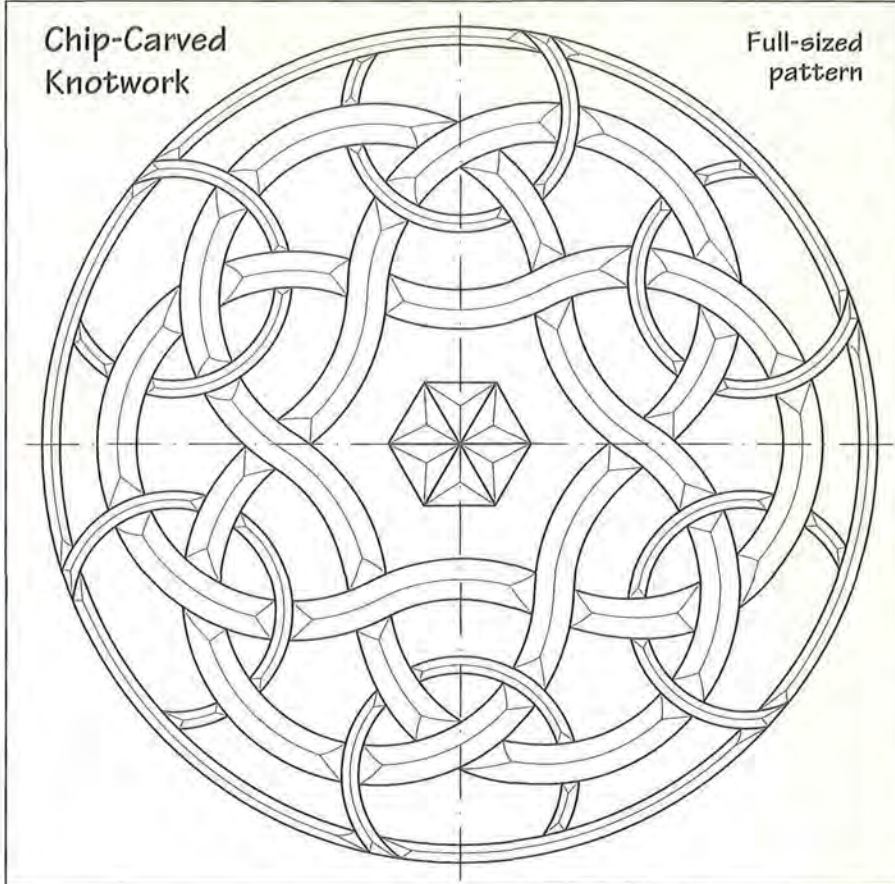

edges, and press the side down firmly to transfer the hole centerpoints to the base. Repeat this procedure to mark the dowel holes on the opposite side of the base and then on the inside face of the top. Drill these $\frac{3}{8}$ " holes $\frac{3}{4}$ " deep.

Step 8. Using a $\frac{1}{4}$ " straight bit, cut a $\frac{1}{4}$ "-deep groove along the inside face of the sides $\frac{3}{8}$ " in from the back edge. (See the Side View drawing page 6 and the Exploded View.) Note: Save this setup for the following step.

Step 9. Using the same setup, rout a stopped groove along the inside face

of the top and base as dimensioned on the Exploded View. To start and stop the groove, scribe a pair of layout lines on the back face of each workpiece and a pair of corresponding lines on your router table's fence.

Step 10. Lay out and plunge-rout stopped dados for the shelves in both sides. (For locations, see the Front View drawing.) Start the dados $\frac{1}{4}$ " from the front edges and rout to the back grooves. Square the stopped front end of each dado with a sharp chisel.

Step 11. Dry-assemble the top, bottom, and sides, temporarily using $\frac{1}{2}$ " lengths of dowel. Check for square and twist. Measure the inside, add the depth of the grooves, and cut the back (D) to fit from $\frac{1}{4}$ " birch plywood.

Step 12. For the three shelves (E), surface a 5×24 " piece of basswood to $\frac{1}{4}$ " thick. Joint one edge, rip it wide enough to fit the dados, then cross-cut the shelves to fit. Insert the shelves and back without glue, disassembling the sides, top, and bottom just enough to do this. Check for fit, and adjust if necessary.

Make the Dovetailed Drawers

Step 1. Measure the two drawer openings in your dry-assembled cabinet. Subtract $\frac{1}{16}$ " from the width and depth and $\frac{1}{8}$ " from the length (side-to-side dimension). Using these dimensions, cut drawer fronts (F, G) for the upper and lower drawers from $\frac{1}{2}$ "-thick butternut. From $\frac{3}{8}$ "-thick basswood, cut backs (H, I) for the drawers to the same dimensions. Now, cut two sides (J, K) for each drawer from $\frac{1}{4}$ "-thick basswood stock.

Step 2. Select and mark an outside face on each drawer part. Then, lay out and cut through dovetails on the parts as dimensioned on the Drawer drawing on *page 6*.

Step 3. Dry-assemble the two drawers to check for fit, and adjust as necessary. Measure the interior dimensions, adding $\frac{3}{16}$ " to the width and length for groove depth. (This leaves an extra $\frac{1}{16}$ " of groove depth.) From $\frac{1}{4}$ "-thick plywood, cut two drawer bottoms (L) to these dimensions.

Step 4. Using a $\frac{1}{4}$ " straight bit, rout $\frac{1}{8}$ "-deep stopped grooves (stopping $\frac{1}{8}$ " from both ends) along the inside faces of the drawer sides $\frac{3}{8}$ " from the bottom edge. (See the Small Drawer front view drawing.) Rout identical through grooves along the inside faces of the fronts and backs.

Step 5. Transfer the full-sized Finger Cutout pattern shown on the Drawer drawing to the center top edge of both drawer fronts. Bandsaw and sand the cutouts to shape. Then, finish-sand the inside faces of all drawer parts.

Step 6. Glue, assemble, and clamp the two drawers. After the glue has dried, sand the joints flush. Next, rout the $\frac{1}{8}$ " and $\frac{1}{16}$ " round-overs on the drawers where shown. Then, finish-sand the exterior drawer surfaces.

Now, Hang the Door

Step 1. Position one of the knife hinges on the top end of the door where shown on the Exploded View.

Center the hinge between the faces, then

trace its outline using a sharp #3 pencil. (See *photo C* for location.)

Note: The entire hinge arm should lie over the door, while the shorter, pinned segment should clear it completely. Repeat this step to mount the hinge on the bottom end of the door. Mark the depth of the hinge leaf on the edge of the door for both hinges. Carefully score the outline in the end grain with a sharp knife, then use a chisel to score the depth line.

Step 2. Carefully pare the hinge gains to depth using a $\frac{1}{4}$ " chisel. Next, fit the hinges in their gains. Using a Vix bit, drill the screw holes, then temporarily screw the hinges to the door.

Step 3. Lay the dry-assembled cabinet on its back. Tap the top and bottom slightly to loosen them, creating clearance for the hinges. Center the door from side to side in its opening, and insert $\frac{1}{16}$ " spacers top and bottom to center the door vertically. Add $\frac{1}{32}$ " spacers to shim the hinged edge of the door out from the cabinet. (Craig used pasteboard from the back of a note pad.) Now, draw a faint line along the hinged edge to mark the door's location on the edge of the side. Double-check the door's position, then secure it with masking tape.

Step 4. Close the hinges, aligning the two leaves precisely. Trace around the pinned segment of the hinge (as much of it as you can) to establish the hinge's location on the top and base. Remove the door, then remove the hinges from the door.

Step 5. Temporarily disassemble the cabinet. Position the hinges on the top and base, then trace around any parts that you couldn't reach before. Score the hinge gains, this time using a chisel for the straight lines. Cut the gains to depth (*photo D*). Then, drill screw holes and attach the hinges to the cabinet.

Photo C: To position hinges on door ends, offset the pinned section to clear the edge. Use paring action to cut the hinge gain in the door's end grain.



Step 6. Dry-assemble the cabinet and attach the door. Check the door for fit and action. If the door binds as you open it, plane a bit of stock from the back of its hinged edge. Now, remove the door from the hinges.

Step 7. To install the bullet catch, drill a $\frac{1}{4}$ " hole in the bottom end of the door using a doweling jig. (For location, see the detail on the Exploded View.) Tap the spring-loaded half of the catch into the hole, then reattach the door to the hinges. With the door closed, establish and mark the location for the mating half of the catch in the base. Temporarily disassemble the cabinet, then drill the hole in the base using your drill press. Insert the catch, then reassemble the cabinet.

Chip-Carve the Optional Knotwork

Step 1. Transfer the full-sized Knotwork pattern on *page 7* to the door face where dimensioned on the Front View drawing.



Photo D: Attach hinges to door, position door on cabinet, align both hinge leaves, and mark hinge location on the top and base. Then, cut cabinet gains as shown.

Figure 5 Cutting order and direction for removing each chip

Note: Cut in clockwise direction if right-handed, counter clockwise if left-handed. Make stop cuts ① and ② first. Hold knife at a constant 65° to the chip you're removing.

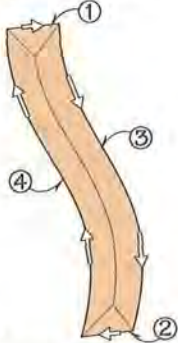

Note: Cut along thick outer lines only. Thin inner lines indicate contour of the completed carving.

Step 2. Using a sharp chip-carving knife, remove each chip by cutting in the order and direction shown in figure 5.

Add the Door Pull and Wall-Mounting Cleat

Step 1. Lay out and cut a centered $\frac{1}{4} \times \frac{1}{2}$ " mortise $\frac{5}{16}$ " deep in the right edge of the door where dimensioned on the Side and Exploded Views. Note: Because of the difficulty of clamping a coopered door, Craig pares out the mortise waste without clamping (which is not difficult in basswood), then squares the corners. If you use a harder wood, clamp the door securely, since you'll need to do more chopping than paring.

Step 2. To make the door pull (M), first cut a $\frac{3}{4} \times \frac{3}{4} \times 6$ " blank from a dark, richly grained wood. (Craig used rosewood.) Cut a $\frac{1}{4} \times \frac{1}{2}$ " tenon $\frac{1}{4}$ " long on one end, locating it $\frac{3}{16}$ " from one face. Test-fit the tenon in the mortise, and adjust as necessary.

Step 3. Transfer the full-sized Door Pull side view pattern shown above to one face of the pull blank. Using a half-round rasp or oscillating spindle sander, form the two arcs along the edges.

Step 4. Transfer the Door Pull top view pattern to the appropriate edge, then bandsaw the profile, staying wide of the line. Carve and/or file the

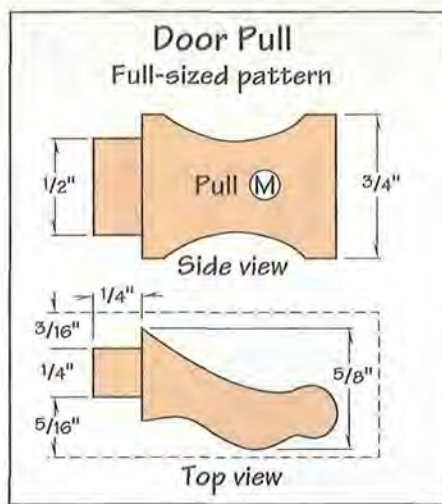

profile to shape. Sand the pull to 220-grit, breaking the corners only slightly. Glue and clamp the pull to the door.

Step 5. To make the two mounting cleats (N), cut a 5x7" blank from $\frac{3}{8}$ "-thick hardwood. Tilt your tablesaw blade to 20° from perpendicular, and bevel-rip the blank in half. Measure the width across the back of the cabinet between the sides, then crosscut the cleats to fit.

Step 6. Using a doweling jig, drill two $\frac{1}{4}$ " holes $\frac{3}{8}$ " deep in both ends of the mounting cleat. Note: You'll use the remaining piece for the mating wall-mounted cleat. Insert dowel centers in the holes, then disassemble the cabinet enough to fit the cleat between the back edges of the two sides. (See the Side View for location.) Square the cleat to the sides with its beveled edge down. Then, press both sides firmly to transfer the hole centerpoints. Disassemble the cabinet and drill $\frac{1}{4}$ " holes $\frac{3}{8}$ " deep in the sides.

Step 7. Cut, groove, and chamfer $\frac{1}{4}$ " dowels $\frac{1}{16}$ " long. Glue them into the cleat holes, leaving $\frac{1}{32}$ " protruding.

Assemble the Cabinet, Then Apply Finish

Step 1. Finish-sand the shelves, the back, and the inside faces of the top, bottom, and sides. Next, cut, groove, and chamfer sixteen $\frac{3}{8} \times \frac{1}{16}$ " dowels, then glue them into the holes in the ends of the sides, leaving $\frac{1}{16}$ " protruding.

Step 2. Glue, assemble, and clamp the cabinet. To do this, first assemble the shelves (without glue) into their

dadoes in one side. Apply intermittent beads of glue to the back groove—avoiding the shelves, which must float freely—then assemble the back to the side. Apply glue to the dowels on one end of the cleat and insert them into the holes in the side. Assemble the opposite side to these parts, applying glue as before. Now, glue, assemble, and clamp the top and bottom to the sides and back. Check for square, then allow the glue to dry.

Step 3. Finish-sand all surfaces that still need it to 220-grit. Remove dust with a tack cloth or compressed air.

Step 4. Apply your choice of finish. (Craig mixed two parts tung oil with one part satin varnish, then thinned this blend 1:1 with mineral spirits. He applied three coats to all surfaces, rubbing between coats with a fine flexible abrasive pad.)

Step 5. Drill and countersink two $\frac{1}{64}$ " shank holes centered between the ends of the wall cleat. Attach the cleat (beveled edge up) to the wall in your chosen location, driving a pair of #8x2" flathead wood screws into a stud. Note: If you can't locate the cleat over a stud, use an appropriate wall-mounting fixture. 

Project designer and builder: Craig Moro

Illustrations: Don and Karen Pauli

Photos: StudioAlex

Produced by: Doug Cantwell