

MATERIAL LIST

	T x W x L
1 Legs (4)	2 1/4" x 2 1/4" x 27 1/8"
2 Upper Cross Supports (2)	2 1/4" x 2 1/4" x 32"
3 Lower Cross Supports (2)	2 1/4" x 2 1/4" x 24 13/16"
4 Stretchers (2)	2 1/4" x 2 1/4" x 55"
5 Diagonal Braces (2)	2 1/4" x 2 1/4" x 30 5/8"
6 Tabletop (1)	1 1/4" x 40" x 84"

Table
(End View)

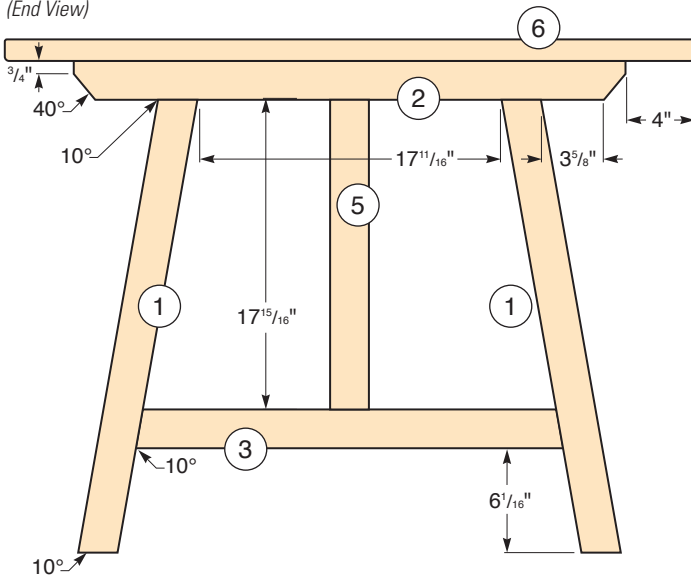

Table
(Front View)

